

# MESA FRÍA PIZZA COMPACTA

MESA FRÍA PIZZA DMFPP / COMPACT PIZZA COUNTER DMFPP



DMFPP-140



DMFCP-140

## CARACTERÍSTICAS GENERALES

- Exterior en acero inox AISI-304 18/10, excepto el respaldo
- Interior en acero inox AISI-304 18/10, con aristas curvas y fondo embutido
- Puertas de apertura reversible, con sistema de cierre automático y burlete magnético (permanece abierta al superar los 90° de apertura)
- Contrapuerta inox embutida
- Luz interior en modelos puerta de cristal
- Encimera granito, con peto trasero y laterales de 180mm
- Expositor de ingredientes independiente, capacidad GN 1-4
- Pies en tubo de acero inox ajustables en altura 125 200 mm
- Unidad condensadora ventilada y extraíble
- Evaporador sistema tiro forzado, con recubrimiento anticorrosión
- Evaporación automática del agua de descarche de serie, excepto modelos pre-instalacion
- Aislamiento de poliuretano inyectado, densidad 40 Kg/m<sup>3</sup>, bajo GWP y cero efecto ODP
- Control digital de temperatura y descarches, eficiente en la gestión del consumo de energía
- Temperatura de trabajo a 32°C ambiente
- Cajoneras inox refrigeradas desmontables sobre guías telescópicas con sistema autocierre

## GENERAL FEATURES

- AISI-304 18/10 stainless steel exterior, except the rear side
- AISI-304 18/10 stainless steel interior, stamped bottom and rounded corners
- Doors with self closing system, blocked opening, magnetic gasket and possibility of changing the opening sense
- Rear-door by stamped steel
- Interior light in glass door models
- Granite working surface with 180mm up stands
- GN ¼ topping unit, included
- Shelves made of plasticized steel wire, height adjustable by stainless steel supports
- AISI -304 18/10 adjustable legs, 125 to 200 mm
- Removable and fan assisted condenser unit
- Fan assisted evaporator, with anticorrosion coating.
- Automatic evaporation of defrost water ass standard, except models preinstalation
- 40 Kg/m<sup>3</sup> density polyurethane insulation, low GWP and zero ODP effect
- Energy efficient digital controller of temperature and defrosts
- Operating temperature 32°C ambient
- Removable stainless refrigerated drawers on telescopic guides with self-closing system

Características técnicas y constructivas sujetas a variación sin previo aviso, todas las fotos deben ser consideradas como una referencia  
Technical and constructive characteristics subject to variation without prior notice, all photos must be considered as a reference

# MESA FRÍA PIZZA COMPACTA

MESA FRÍA PIZZA DMFPP / COMPACT PIZZA COUNTER DMFPP

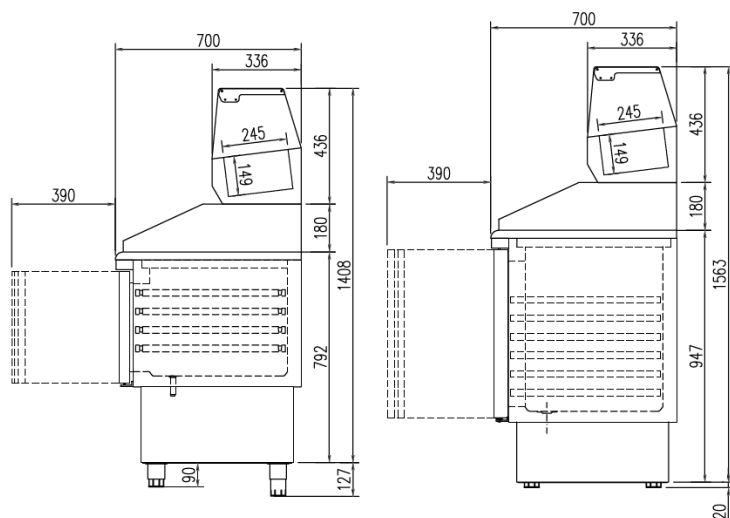

Modelo Model Modèle	Largo Length Longueur mm	Alto Height Hauteur mm	Fondo Depth Profondeur mm	Rango Range Gamme	Estantes Shelves Étagères	Pares de guías Sets of slides Kit de guides	Capacidad Capacity Exposition L	Capacidad GN Capacity GN Exposition GN	Voltaje Voltage Tension	Refrig. Coolant Frigorigène	Potencia Frig. Frig Power Puissance Frig. W	Consumo Nominal Nominal Consumption Consommation Nominale W
DMFPP-140	1370	890	700	0°C +8°C	3	3	264	GN 1/4: 5 uds	230 V - 50 Hz	R-290	1004	614
DMFCP-140	1370	970	700	0°C +8°C	3	3	399	GN 1/4: 5 uds	230 V - 50 Hz	R-290	1004	614

Características técnicas y constructivas sujetas a variación sin previo aviso, todas las fotos deben ser consideradas como una referencia  
 Technical and constructive characteristics subject to variation without prior notice, all photos must be considered as a reference